

Winches



Leading manufacturer of hand winches

TALBOT design & manufacture winches for more than 30 years. The company offers one of the largest ranges of manual winches under TDE trademark.

Designed for industrial or private applications, our winches cover a wide variety of applications:

- Ratchet winch up to 3 000 kg
- Lifting winch (steel and stainless steel) up to 2 400 kg (1st layer)
- Worm gear winch up to 900 kg
- Multi-purpose wall mounted winch up to 200 kg
- Hauling electric winch up to 2 000 kg
- Special winch (dedicated applications) for OEM and equipment manufacturers.

TDE lifting winches include a built-in self-activated friction brake and a protective structure. They conform to European standards and are CE / GS certified.

All our winches undergo the most rigorous durability and capacity tests for optimum quality and safety.

Winches range



Compact winch (page 3)
Multi-purpose winch.



Brake winch (page 4)
For lifting purpose. Includes a self-braking system.



Lifting brake winches TPV (page 6)
For lifting purpose. Capacity up to 2 400 kg (1st layer).



Boat trailer winch TS (page 7)
Safety winch for boats up to 3 000 kg



Ratchet winch (page 8)
Reversible ratchet 1, 2 or 3 speeds. Removable handle.



Electrical hauling winch and worm gear winch (please contact us). Capacity up to 2 000 kg.

How to select your winch

Winch selection

The winch must be carefully selected depending on your application, the load, the type of cable or webbing strap fitted and the specific conditions of operation required. The technical and safety specifications in this leaflet have been designed to assist you in selecting the product you need.

Unless otherwise required by your application, we recommend the selection of a brake winch with gear protection, suitable for most lifting or pulling applications and offering the most appropriate level of safety.

Operation

All winches are supplied without cable or webbing strap. It is required to control the winch after assembly of the cable or the webbing strap by conducting a commissioning test in accordance with local safety standards.

The winch has to be used and maintained according to the manufacturer's instructions. Non compliance to these instructions may create potential safety hazards.

Warning - it is prohibited :

- To lift and transport people ;
- For people to stand under the load
- To lift loads with a cable line not perpendicular to the drum axel
- To swing the load during the winching operation
- To hold a load sustained by the winch beyond the operation time.
- To unwind the loose cable and then release the load.
- And particularly regarding the ratchet winches :
 - To use the winch for lifting purpose
 - To manipulate the ratchet : - when the winch is holding a load
 - when the load has not been secured safely.

Compact lifting winches



- Compact and sturdy lifting winches for loads up to 200 kg.
- Low force on the handle (3 kg).
- Permanent brake and protection cover for greater safety.
- Operation noise free.
- Ideal for a short moving stroke (2 m).
- Patent pending, TDE is a Trademark of Talbot Decoupage Emboutissage



Items

Note : Winches supplied without cable or webbing strap

Type	CS100	CS100MD	CS100PS	CS200	CS200MD
	Standard	Quick attach handle	For webbing strap	Standard	Quick attach handle
Item No	PF63201	PF63202	PF63204	PF63301	PF63302
Maximum rated capacity	100 kg	100 kg	170 kg	200 kg	200 kg
Gear ratio	1/7	1/7	1/7	1/14	1/14
Force on handle at 50% of rated capacity	3 kg	3 kg	3 kg	3 kg	3 kg
Drum cable capacity, Ø 3 mm	9 m	9 m	-	4 m	4 m
Drum cable capacity, Ø 4 mm	-	-	-	2 m	2 m
Webbing strap capacity, 1 mm thick / 20 mm wide	-	-	4 m	-	-
Weight	1,8 kg	1,8 kg	1,8 kg	1,8 kg	1,8 kg
Number of winches per box	10	10	10	10	10

Maintenance kit

Type	CS100	CS100MD	CS100PS	CS200	CS200MD
Cable grip	PF56006	PF56006	-	PF56001	PF56001
Handle kit	PF56051	-	PF56051	PF56051	-
Quick attach handle kit	-	PF56083	-	-	PF56083

Note: These winches are not designed for moving people and must not be used for that purpose

Dimensions (mm)

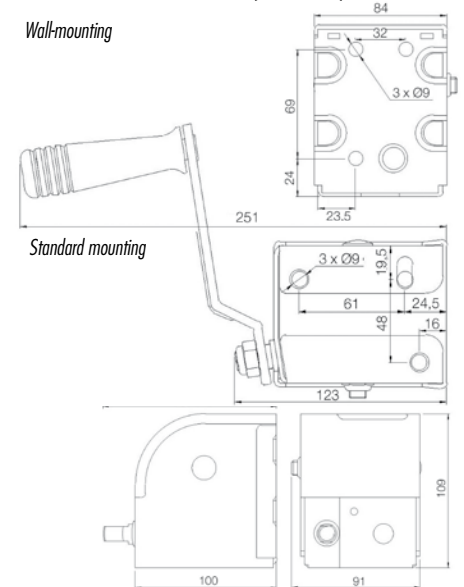

Lifting kit for home application

Ready for use kit designed for garage, outside use, trap doors or retractable stairs, etc....



Lifting winch CS100LC
Capacity 100kg
Galvanised steel

+



Ready for use wire rope
Ø 3 mm
Length 10 ou 15 m
SWL 580kg

+



Pulley
Sheave Ø 25 mm
or sheave Ø 35 mm
SWL 580kg

+



Cable grip connection
For Ø 3 mm cable

Brake winches



- Winch with a security self-braking system for lifting applications. The load can be held without any action on the handle.
- Cable and webbing strap winch types.
- Capacity up to 650 kg for lifting purpose (last layer).
- Surface treatment : zinc plated or stainless steel 316L for corrosive environments.

Security : self-braking system (Constant positive holding of the load)	Strong and protective body, with gear protection	Easy cable mounting, without drum removal	Webbing strap type	Zinc plated, black finishing

Brake winches with gear protection

Winches supplied without any cable or webbing strap



Cable winch range, with gear protection Item No	4AFMD PF54424	4AFD PF53403	6AFD PF53603	8AFD PF53803	12AFD PF53103	20AFD PF532003
Lifting capacity : last layer	80 kg	190 kg	240 kg	270 kg	490 kg	650 kg
first layer	190 kg	340 kg	500 kg	650 kg	900 kg	1 180 kg
Rolling load capacity on a 20% incline	350 kg	500 kg	750 kg	900 kg	1 500 kg	2 500 kg
Drum-Ø	27 mm	40 mm	45 mm	54 mm	63 mm	76 mm
Ø wire rope	3 mm	4 mm	5 mm	6 mm	7 mm	8 mm
Length of the wire rope	8 m	10 m	12 m	19 m	12 m	10 m

Winch supplied equipped with 50 mm webbing strap and hook.



Supplied equipped with webbing strap with hook and gear protection Item No (webbing strap 50mm)	-	4AFDS PF53403S	6AFDS PF53603S	8AFDS PF53803S	12AFDS PF53103S	20AFDS PF532003S
Rolling load capacity on a 20% incline	-	400 kg	700 kg	900 kg	1 500 kg	2 200 kg
Length of the webbing strap	-	4,6 m	6 m	8 m	8 m	8 m

Winch supplied equipped with wire rope with hook.



Cable winch range, with gear protection Item No	-	4AFDW PF53403W	6AFDW PF53603W	8AFDW PF53803W	12AFDW PF53103W	20AFDW PF532003W
Rolling load capacity on a 20% incline	-	400 kg	700 kg	900 kg	1 500 kg	2 200 kg
Ø wire rope	-	4 mm	5 mm	6 mm	7 mm	8 mm
Length of the wire rope	-	10 m	10 m	10 m	10 m	10 m

Brake winches in stainless steel 316L with gear protection

Winches supplied without any cable or webbing strap



Cable winch range, with gear protection Item No	4AFMID PF53417	4AFID PF53418	6AFID PF53619	8AFID PF53824	12AFID PF53119
Lifting capacity : last layer	80 kg	180 kg	240 kg	270 kg	490 kg
first layer	190 kg	340 kg	500 kg	650 kg	900 kg
Rolling load capacity on a 20% incline	350 kg	500 kg	750 kg	900 kg	1 500 kg
Drum-Ø	27 mm	40 mm	45 mm	54 mm	63 mm
Ø wire rope	3 mm	4 mm	5 mm	6 mm	7 mm
Length of the wire rope	8 m	10 m	12 m	19 m	12 m

Common data

Min. load for the brake function	10 kg	10 kg	10 kg	10 kg	10 kg	10 kg
Gear ratio	1/2,57	1/2,57	1/3,5	1/4,85	1/9,71	1/9,71
Weight	2,2 kg	2,7 kg	3,7 kg	5,5 kg	7,4 kg	7,8 kg
Number of winches per box (Except for the winches in stainless steel)	10	8	6	4	3	2

***Important :** These winches are not designed for the transport of people and must not be used for this purpose.

Options (available in master pack only)



Handle with a foldable grip
Option M2
(for all winches)



Free-wheeling drum (without load)
Option M4
(only for 20AFD)



Wall-mounting accessories
Carrier plate for 3 to 5N1 & 4AF : PF00471
Other dimensions : PF01411

Maintenance kit

Winch type	4AFM	4AF	6AF	8AF	12AF	20AF	4AFMI	4AFI	6AFI	8AFI	12AFI
Handle kit	PF56060	PF56060	PF56061	PF56062	PF56063	PF56064	PF56070	PF56070	PF56071	PF56072	PF56073
Cable grip kit	PF56001	PF56001	PF56002	PF56003	PF56004	PF56004	PF56010	PF56010	PF56011	PF56012	PF56013

Dimensions (mm)

Important : At least 3 fixing points are required (4AFM : 2 fixing points)

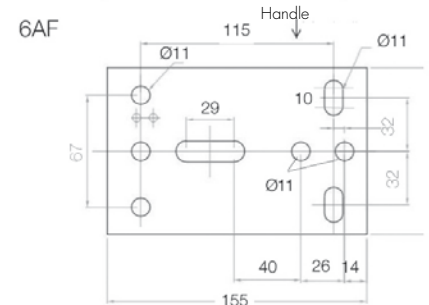
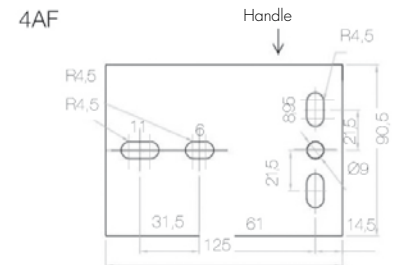
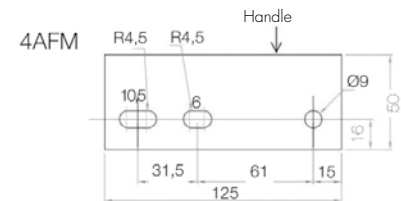
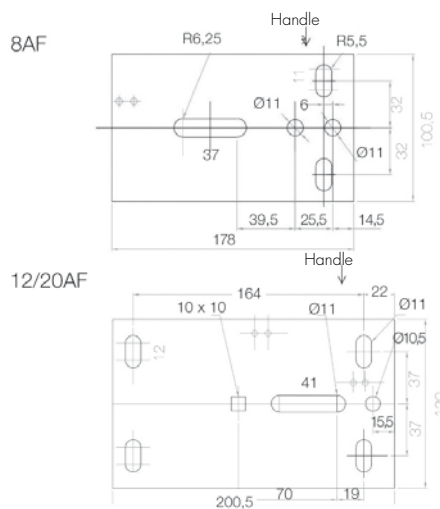
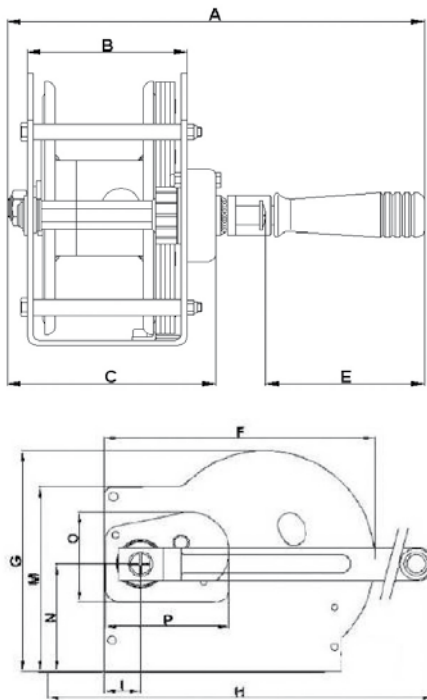

Winch	4AFM	4AF	4AFI	6AF	6AFI	8AF	8AFI	12AF	12AFI	20AF
A	211	250	245	265	265	265	270	294	294	294
B	50	90,5	88,5	99	99	100	100	119,5	119,5	119,5
C	78	117	117	132	132	132	130	155	155	155
E	100	100	96	100	100	100	100	100	100	100
F	126	128	128	161	165	200	200	214	214	214
G	96	96	96	128	130	167	167	170	170	170
H	195	197	202	240	232	290	290	295	295	330
I	27	27	27	27	27	27	27	28	28	28
M	80	80	80	117	117	140	140	140	140	140
N	31	31	31	58	58	81	81	81	81	81
O	68	68	58	68	58	68	58	68	58	68
P	92	92	92	92	92	92	92	92	92	92

Lifting brake winches TA and TPV series



- Supplied without cable (option with wire rope and hook for TPV900, 1200 and 1600)
- Removable handle.
- TA winches for wall mounting application.
- Galvanised steel and black plastic cover.

Patent pending, TDE is a Trademark of Talbot Decoupage Emboutissage

Winches TA and TPV series: Reliability and maximum comfort of use



Permanent & reliable load brake

The internal load brakesystem is automatically activated as soon as the wire rope is under tension with or without handle.

2 speeds = More comfort

Choice between 2 hauling speeds for the TPV1600, 2200 and 3000 and TA1200. Allows the change of speed while the winch is in use.

Mounting

Standard mount
The TPV winch can be mounted on a plate.

Wall mounting
The TA winch can be directly mounted on a wall.

Option : TPV Winch with 2 handles

TPV Winch designed to be used with a handle on the right side or with a second handle on the left side.

Items



Winch supplied without rope Item No	TPV900 PF70901	TPV1200 PF701201	TPV1600 PF701601	TPV2200 PF702201	TPV3000 PF702000	TA900 PF70902	TA1200 PF701202
Lifting capacity (kg)	325	500	560	650	1 500	325	500
Last layer	700	900	900	1040	2 400	700	900
Rolling load capacity (kg) on 20% incline	1 200	1 600	1 700	2 200	3 000	-	-
Gear ratio	1/4,85	1/9,71	1/4,85 and 1/9,71	1/4,85 and 1/9,71	1/10 and 1/21,77	1/4,85	1/4,85 and 1/9,71
Drum-Ø (mm)	54	63	63	72	80	54	63
Wire rope length (m)	Ø 6 mm	16	13	13	-	15	13
	Ø 7 mm	-	10	10	-	-	10
	Ø 8 mm	-	-	-	10	-	-
	Ø 9 mm	-	-	-	-	-	-
Handle length (mm)	250	250	290	290	290	290	290
Number of speeds	1	1	2	2	2	1	2
Handle	Fixed	Fixed	Removable	Removable	Removable	Removable	Removable
Winch weight (kg)	5,7	6,0	6,0	6,2	21	5,7	6,0
Units per box	4	4	4	4	1	4	4

Maintenance and accessories

Handle



Type	Item No
Fix (length 250 mm)	PF56416
Removable (length 290 mm)	PF56411

Cable grip



Type	Item No
TA/TPV 900	PF56003
TA/TPV 1200, TPV1600, TPV2200	PF56004
TPV 3000	PF56005

Adaptation plate (for TPV900/1200/1600/2200) for direct tube mounting (square tube of 50 mm maximum).



Type	Item No
Plate to weld	PF56415
Plate to fix by screws	PF56413

Dimensions and fixings (mm)

	TPV900	TPV1200	TPV1600	TPV2200	TPV3000	TA900	TA1200
A	Ø11	Ø11	Ø11	Ø11	Ø13	Ø11	Ø11
B	24	24	24	24	60,25	24	24
C	70	70	70	70	128	70	70
D	22	22	22	22	10,5	28	28
E	24,5	24,5	24,5	24,5	24,75	24,5	24,5
F	28	28	28	28	25	130	130
G	130	130	130	130	210	48,5	48,5
H	36	36	36	36	-	290	290
I	48,5	48,5	48,5	48,5	85	86	86
J	250	250	290	290	290	140	140
K	186	186	186	186	252	186	186
L	390	343	343	343	518,8	390	343
M	212	212	212	212	220,5	23	23
N	119	119	119	119	177,5	43	43
O	246	273	273	273	335,4	20	20
P	-	-	-	-	-	60	60
Q	-	-	-	-	-	23	23
R	-	-	-	-	-	10,5	10,5
S	-	-	-	-	-	256	273
T	-	-	-	-	-	119	119
U	-	-	-	-	-	272	272

TPV3000

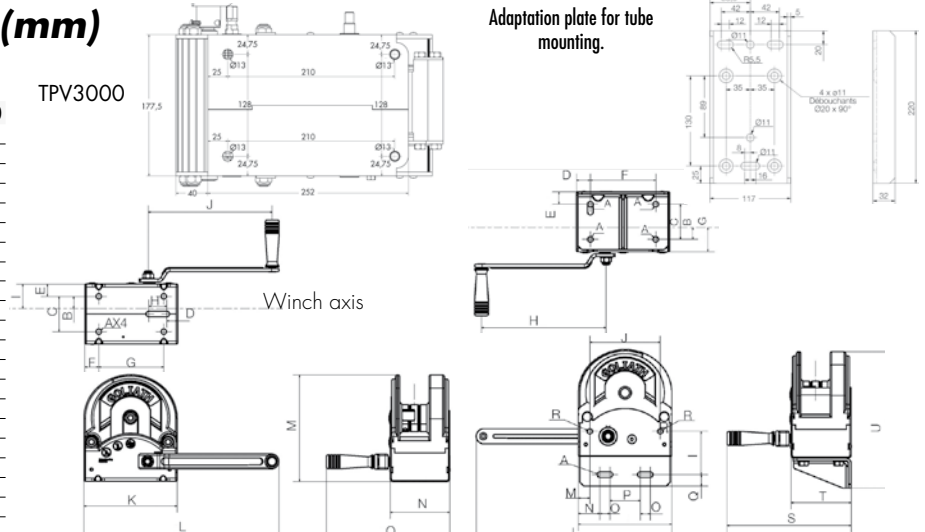

Boat trailer security winch TS Series



- Winch delivered complete with strap and hook.
- Colour code indicates strap pulling capacity.
- Galvanized steel and plastic carter.

Patent pending, TDE is a Trademark of Talbot Decoupage Emboutissage

Winch TS series: An easy to use safety winch



Simplicity

Push the strap guide in lower position and pull off the strap... Hitch the boat up. After the tension of the strap* ... the boat is automatically secured.

Constant security

The winch holds the boat... you can unhand the handle.

Comfort of use

2 speeds to reduce the effort. During pulling operation the winch holds the boat even without action on handle. Up winding without load 10 times faster.

Items



Winches supplied with strap and hook	TS700	TS800	TS900	TS1200	TS1600	TS2200	TS3000	
Item No	PF70700	PF70800	PF70900	PF701200	PF701600	PF702200	PF703000	
Hauling capacity (20% incline) (kg)	700	800	900	1 200	1 600	2200	3 000	
Gear ratio	Speed 1	1/3,5	1/4,85	1/4,85	1/4,85	1/4,85	1/10	
	Speed 2	-	-	1/9,71	1/9,71	1/9,71	1/21,77	
Strap	Length (m)	6,5	8	8	8	8	13	
	Colour	Black	Black	Yellow	Yellow	Green	Green	Red
Max force on handle in hauling operation	Boat weight	560 kg	590 kg	675 kg	900 kg	1 200 kg	1 600 kg	2 400 kg
	Force (kg)	700 kg	780 kg	900 kg	1 200 kg	1 600 kg	2 200 kg	3 000 kg
Handle length (mm)	200	250	290	250	290	290	290	
Winch weight (kg)	4,7	5,7	5,7	6,1	6,1	6,5	21	
Units per box	4	4	4	4	4	4	1	

Maintenance and accessories

** Strap maintenance is achieved through replacement of the complete drum sub-assembly, delivered with strap and hook. Available at your local authorised distributor



Type	Drum complete with strap, hook and strap guide**
TS700	PF56405
TS800	PF56406
TS900	PF56407
TS1200	PF56408
TS1600	PF56409
TS2200	PF56412
TS3000	PF56427 (strap and hook)



Handle length	Item No
200 mm	PF75083
250 mm	PF56410
290 mm	PF56411



Adapter plate :
For TS (Except TS3000) **PF56413**
(1) Dimensions page 6

Dimensions and fixings (mm)



Be careful: The instructions of the operation manual supplied with the winch have to be strictly followed

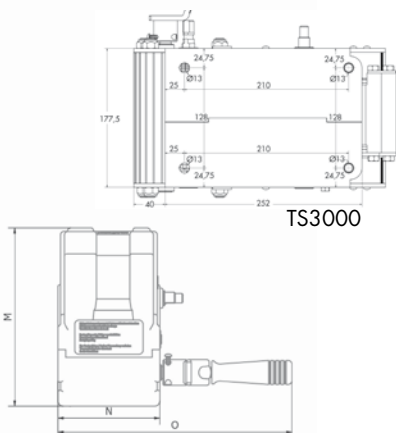
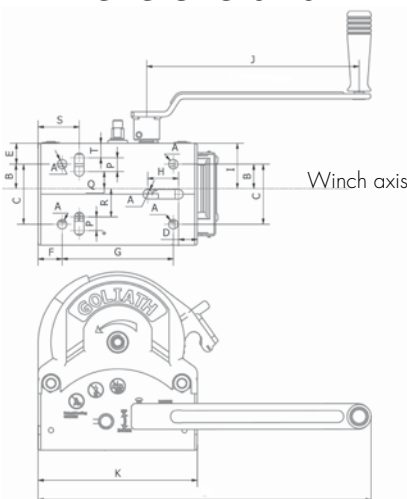

	TS700	TS800	TS900	TS1200	TS1600	TS2200	TS3000
A	Ø11	Ø11	Ø11	Ø11	Ø11	Ø11	Ø13
B	28,5	28,5	28,5	28,5	28,5	28,5	60,25
C	70	70	70	70	70	70	128
D	22	22	22	22	22	22	10,5
E	24,5	24,5	24,5	24,5	24,5	24,5	24,75
F	28	28	28	28	28	28	25
G	130	130	130	130	130	130	210
H	46	36	36	36	36	36	-
I	53	53	53	53	53	53	85
J	200	250	290	250	290	290	290
K	186	186	186	186	186	186	252
L	430	390	430	390	430	430	518,8
M	183	208	208	208	208	208	220,5
N	119	119	119	119	119	119	177,5
O	273	273	273	273	273	273	335,4
P	17	-	-	-	-	-	-
Q	13,5	-	-	-	-	-	-
R	26,5	-	-	-	-	-	-
S	48	-	-	-	-	-	-
T	22,5	-	-	-	-	-	-

Pulling winches with ratchet



- Winches only for pulling applications (0% incline or load independently secured)*
- Reversible ratchet 3 positions except 3N1 (2 positions)
- Wide range, 1 to 3 speeds
- Pulling capacity up to 2 700 kg
- Surface treatment : zinc plated

Items

Winches supplied without any cable or webbing strap

Cable winch range	3N1	5N1	7N1	9N1	16N2	16N2F	25N3F
Item No	PF50301	PF50501	PF50701	PF50901	PF51601	PF51607	PF52507
Pulling capacity on a 0% incline)*	470 kg	596 kg	723 kg	894 kg	1 556 kg	1 556 kg	2 741 kg
Gear ratio	Speed 1	1/3,5	1/4,85	1/4,85	1/4,85	1/4,85	1/4,25
	Speed 2	-	-	-	1/9,71	1/9,71	1/10,92
	Speed 3	-	-	-	-	-	1/21,85
Drum-Ø	25 mm	22 mm	28 mm	28 mm	28 mm	28 mm	50 mm
Hand-brake	No	No	No	No	No	Yes	Yes
Weight	2,0 kg	3,0 kg	4,6 kg	6,0 kg	6,9 kg	7,8 kg	13,1 kg
Number of winches per box	10	7	5	4	3	3	1

Set of screws for webbing strap : PF56020

Each Goliath ratchet winch can be fitted independently with a cable or a webbing strap. Only the fixing sets are different.

Mounting a webbing strap on a Goliath ratchet winch simply requires a set of fixing screws to be ordered for replacement of the usual cable grip.



Cables and winding capacities

Winch type	3N1	5N1	7N1	9N1	16N2	16N2F	25N3F
Cable-Ø (mm)	3	5	5	6	7	7	8
Max. length (m)	22	17	32	21	14	14	14
Cable-Ø (mm)	4	6	7	7	8	8	9
Max. length (m)	13	10	14	16	10	10	13

Fixing accessories :

See page 5 (as for brake winches)

Maintenance kit

Winch type	3N1	5N1	7N1	9N1	12N2	16N2F	25N3F
Handle kit	PF56051	PF56052	PF56052	PF56052	PF56054	PF56054	PF56054
Ratchet kit	PF56101	PF56102	PF56103	PF56103	PF56103	PF56103	PF56104
Hand-brake + ratchet kit	-	-	-	-	-	PF56110	PF56111
Cable grip kit	PF56001	PF56002	PF56002	PF56004	PF56004	PF56004	PF56005

***Important :** These winches are neither designed according to EC standard nor for the transport of people or for lifting applications and must not be used for such purposes. Do not reverse or change the ratchet position until the load has been secured safely.

Dimensions (mm)

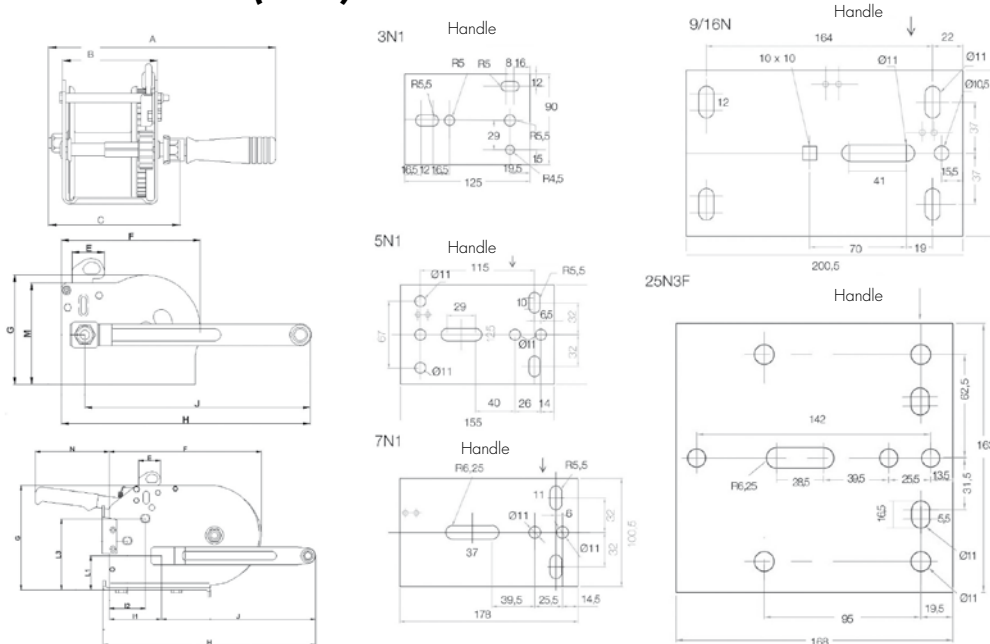

Important : At least 3 fixing points are required

Winch type	3N1	5N1	7N1	9N1	16N2	16N2F	25N3F
A	230	240	242	270	290	290	345
B	90	99	100	120	120	120	163
C	130	140	142	165	175	175	230
E	38	38	38	38	38	38	38
F	125	161	200	214	214	214	265
G	100	127	166	171	171	171	190
H	200	240	240	253	312	312	348
I1	27	27	27	40	52	52	88
I2	-	-	-	-	30	30	66
J	174	213	213	213	260	260	260
L1	30	57	81	83	83	83	55
L3	-	-	-	-	-	-	76
M	88	118	140	141	141	141	175
N	-	-	-	-	-	160	130